



California
Subject
Examinations for
Teachers®

TEST GUIDE

SCIENCE SUBTEST III: PHYSICS

Sample Questions and Responses and Scoring Information

Copyright © 2006 by National Evaluation Systems, Inc. (NES®)

"California Subject Examinations for Teachers," "CSET," and the "CSET" logo are registered trademarks of the California Commission on Teacher Credentialing and National Evaluation Systems, Inc. (NES®).

"NES®" and its logo are registered trademarks of National Evaluation Systems, Inc.™

CS-TG-QR123X-03

Sample Test Questions for CSET: Science Subtest III: Physics

Below is a set of multiple-choice questions and constructed-response questions that are similar to the questions you will see on CSET: Science Subtest III: Physics. You are encouraged to respond to the questions without looking at the responses provided in the next section. Record your responses on a sheet of paper and compare them with the provided responses.

Scientific calculators **will be provided** for the examinees taking General Science Subtests I and II, as well as the specialty subtests of Biology/Life Science, Chemistry, Earth and Planetary Science, and Physics. Refer to the current CSET registration bulletin for a list of the calculator models that may be provided. Directions for the use of the calculator will not be provided at the test administration. You will not be allowed to use your own calculator for CSET: Science subtests.

CONSTANTS

Description	Value
Acceleration of gravity on Earth (g)	9.8 m/s ²
Speed of light in a vacuum (c)	3.00×10^8 m/s
Planck's constant (h)	6.63×10^{-34} J·s = 4.14×10^{-15} eV·s
Electron rest mass	9.11×10^{-31} kg
Proton rest mass	1.67×10^{-27} kg
Charge of electron	-1.60×10^{-19} C
Coulomb's constant (k_e)	9.0×10^9 N·m ² /C ²
Boltzmann's constant (k)	1.38×10^{-23} J/K
Gas constant (R)	$8.31 \frac{\text{L}\cdot\text{kPa}}{\text{mol}\cdot\text{K}}$
Gravitational constant (G)	6.67×10^{-11} N·m ² /kg ²

TRIGONOMETRIC FUNCTIONS

Description	Value
sine 30°	0.500
sine 45°	0.707
sine 60°	0.866
cosine 30°	0.866
cosine 45°	0.707
cosine 60°	0.500

FORMULAS

Description	Formula
Quadratic formula	$\frac{-b \pm \sqrt{b^2 - 4ac}}{2a}$
Constant acceleration	$v = v_i + at$ $x = x_i + v_i t + \frac{1}{2}at^2$ $v_f^2 - v_i^2 = 2a(x_f - x_i)$
Circular motion	$a = \frac{v^2}{r}$ $\theta = \theta_i + \omega_i t + \frac{1}{2}\alpha t^2$ $\omega = \omega_i + \alpha t$ $v = r\omega$ $a = r\alpha$ $\tau = I\alpha$
Spring	$F = -kx$ $PE = \frac{1}{2}kx^2$ $T = 2\pi\sqrt{\frac{m}{k}}$ $f = \frac{1}{2\pi}\sqrt{\frac{k}{m}}$ $\omega^2 = \frac{k}{m}$
Pendulum	$T = 2\pi\sqrt{\frac{L}{g}}$ $\omega^2 = \frac{g}{L}$
Speed of waves in a string	$v = \sqrt{\frac{T}{\mu}}$
Standing wave condition for a string fixed at both ends	$2L = n\lambda, n \text{ is an integer}$
Standing wave condition for a string fixed at one end	$4L = n\lambda, n \text{ is odd}$
Doppler effect	$f' = f_0 \left(\frac{V \pm V_o}{V \pm V_s} \right)$

FORMULAS (continued)

Description	Formula
Optics	$n_1 \sin \theta_1 = n_2 \sin \theta_2$ $n = \frac{c}{v}$ $\frac{1}{f} = \frac{1}{p} + \frac{1}{q}$
Thermodynamics	$\Delta U = nC_v \Delta T$ $\Delta Q = mc \Delta T$ $PV = nRT$ $\frac{1}{2} m \bar{v}^2 = \frac{3}{2} kT$
Magnetism	$\mathbf{F} = q\mathbf{v} \times \mathbf{B}$ $\mathbf{F} = I\mathbf{l} \times \mathbf{B}$
Electricity	$F = \frac{kq_1q_2}{r^2}$ $V = IR$ $P = IV$ $E = \frac{F}{q}$ $V = \frac{\omega}{q}$ $Q = CV$

NOTES FOR PHYSICS TEST

Not all formulas necessary are listed, nor are all formulas listed used on this test.

In questions on electricity and magnetism, the term *current* refers to "conventional current" and the use of the right-hand rule is assumed.

While attention has been paid to significant figures, no answer should be considered incorrect solely because of the number of significant figures.

1. A ball is thrown with an initial velocity of 20 m/s at an angle of 30° above the horizontal. What is the instantaneous vertical velocity of the ball when it is 5.1 m above the release point? ($g = 9.8 \text{ m/s}^2$)
- A. 0.2 m/s
 - B. 6.6 m/s
 - C. 10 m/s
 - D. 17 m/s
2. A uniform disk with a mass of 20 kg and radius of 1.5 m is fixed by a pivot at its center. From rest, the disk undergoes an angular acceleration of 0.50 rad/s^2 . What is the displacement after 3.0 s?
- A. 1.5 rad
 - B. 2.3 rad
 - C. 2.7 rad
 - D. 3.4 rad

3. Use the diagram below to answer the question that follows.

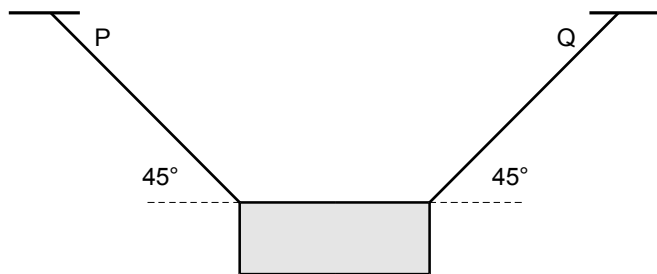

The diagram shows a 4.0 kg object suspended from two cables, both of which are at 45° angles with the horizontal. What is the tension in cable P?

- A. 20 N
- B. 28 N
- C. 39 N
- D. 55 N

4. Use the diagram below to answer the question that follows.

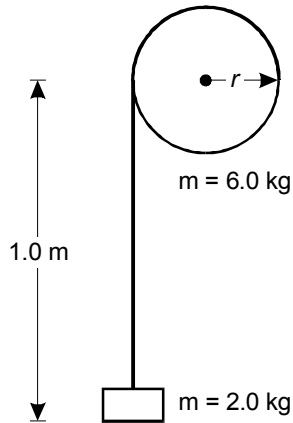

The diagram shows a frictionless wheel with a cable wrapped around it and a block attached to the end of the cable. The wheel has a mass of 6.0 kg and the block has a mass of 2.0 kg . The block is released from rest and drops as the cable unwinds. When the block has dropped 1.0 m , its velocity is 2.8 m/s . What is the kinetic energy of the wheel?

- A. 0 J
- B. 8.4 J
- C. 12 J
- D. 20 J
5. Which of the following is required in order for momentum to be conserved in a system of objects that collide?
- A. Unbalanced forces act only between the objects in the system.
- B. Two or fewer objects are in the system.
- C. Contact time between the objects in the system is very short.
- D. Objects in the system are elastic.

6. Use the graph below to answer the question that follows.

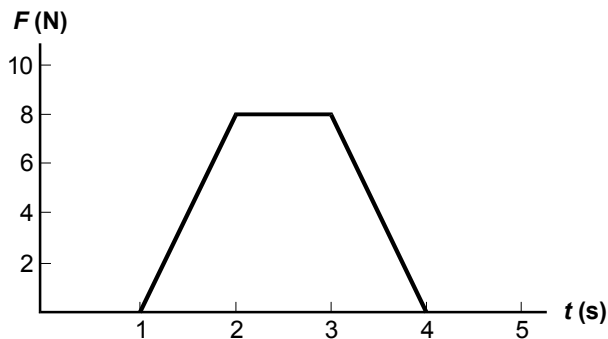

The graph above shows the magnitude of a force as a function of time. At $t = 0$, a 10 kg object is moving at 4.0 m/s. The force shown on the graph is applied to the object in the direction of motion. What is the momentum of the object at $t = 5$?

- A. 16 kg·m/s
- B. 24 kg·m/s
- C. 40 kg·m/s
- D. 56 kg·m/s
7. An ideal gas is contained in a cylinder with a moveable piston. The cylinder is immersed in a water bath to maintain the temperature at 273 K. The piston slowly compresses the gas and does 140 J of work. Which of the following must be true?
- A. The average kinetic energy of the gas molecules increases by 140 J.
- B. The change in entropy of the gas is 140 J.
- C. The internal energy of the gas increases by 140 J.
- D. The heat energy transferred to the water bath is 140 J.

8. Scientists make an insulated container to hold 4.0 moles of nitrogen at a pressure of 10^5 Pa and a temperature of 200 K. What is the size of the container? (1 atm = 101 kPa)
- A. 4 liters
 - B. 8 liters
 - C. 17 liters
 - D. 67 liters
9. Common fluorescent light bulbs consist of glass tubes containing low-pressure mercury vapor. Electrodes at each end allow current to flow, which converts the mercury vapor to a plasma. The plasma can reach temperatures of 10^4 K. Which of the following best explains why the fluorescent bulb feels cool to the touch?
- A. The light emitted is in the visible range, so little is infrared radiation.
 - B. The plasma exists for a short time, so the heat is quickly dissipated.
 - C. The pressure in the bulb is low, so heat is not conducted to the glass.
 - D. The density of the plasma is low, so the amount of heat is small.
10. Which of the following changes in a string will increase the frequency of its vibration?
- A. increased mass
 - B. increased length
 - C. increased tension
 - D. increased cross section

11. Use the diagram below to answer the question that follows.



The diagram shows a wave pulse with velocity v_1 traveling in a light string attached to a heavy string. Which of the following best represents the shape of the string after the pulse has passed the boundary between the two strings?

- A. Option A shows a crest pulse on the light string moving to the left with velocity v_1 . On the heavy string, a trough pulse is moving to the right with velocity v_2 .
- B. Option B shows a flat light string and a crest pulse on the heavy string moving to the right with velocity v_2 .
- C. Option C shows a trough pulse on the light string moving to the left with velocity v_1 . On the heavy string, a crest pulse is moving to the right with velocity v_2 .
- D. Option D shows a trough pulse on the light string moving to the left with velocity v_1 . On the heavy string, a trough pulse is moving to the right with velocity v_2 .

12. Use the diagram below to answer the question that follows.

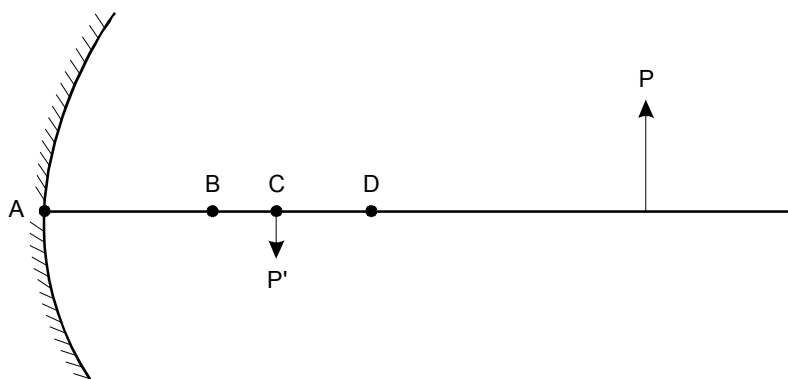

A curved mirror forms an image P' of an object P . Which of the following best indicates the location of the focal point of the mirror?

- A. A
- B. B
- C. C
- D. D

13. Use the diagram below to answer the question that follows.

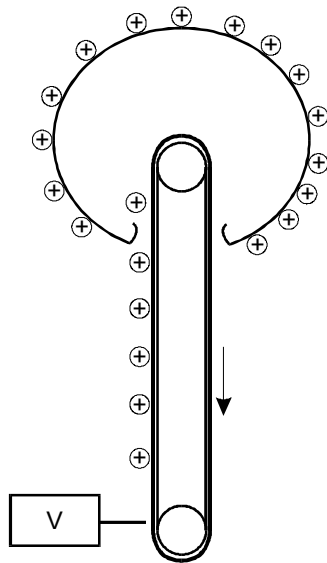

The diagram shows a Van de Graaff generator, which is a laboratory device for building up high voltage. The hollow metal sphere collects the charge while a belt carries charge from the voltage source to the sphere. The generator is 100% efficient and the potential difference between the belt and the sphere is 75 kV. Which of the following is the power needed to supply charge to the sphere at a rate of $160 \mu\text{C/s}$?

- A. $2.1 \times 10^{-8} \text{ W}$
- B. 0.083 W
- C. 12 W
- D. $4.7 \times 10^8 \text{ W}$

14. Use the circuit diagram below to answer the question that follows.

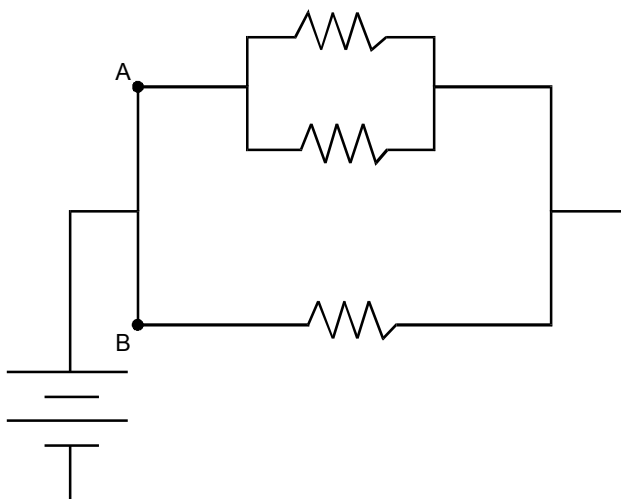

The diagram shows a circuit with three identical resistors. Which of the following is the ratio of the current through point *A* to the current through point *B*?

- A. $\frac{1}{2}$
- B. $\frac{2}{3}$
- C. 1
- D. 2

15. Which of the following postulates is necessary for the Bohr model of the atom?
- A. Special relativity is required for correct velocity calculations as electrons are moving at speeds near the speed of light.
 - B. The intensity of a photon wave at a point determines the probability that there is a photon particle at that point.
 - C. Electrons exist as both wave and particle, but wave and particle properties can not be exhibited simultaneously.
 - D. The laws of classical mechanics apply to electrons orbiting in a stationary state, but different rules apply during transitions between states.

16. Use the diagram below to complete the exercise that follows.

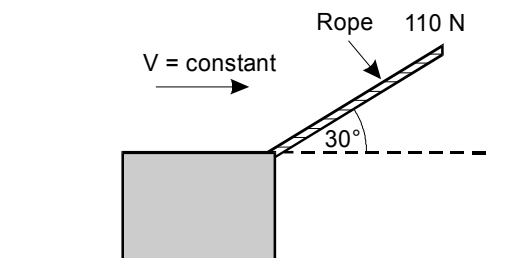

A block with a mass of 25 kg is pulled across a rough horizontal surface at a constant velocity by a rope that makes an angle of 30° with the horizontal, as shown in the diagram above. The tension in the rope is 110 N. Friction is NOT negligible.

- Draw a free body diagram of the block showing all forces acting on the block.
- Write equations for the net x and y components of the force.
- Calculate the coefficient of kinetic friction between the block and the surface. Show your work.

17. Use the diagrams below to complete the exercise that follows.

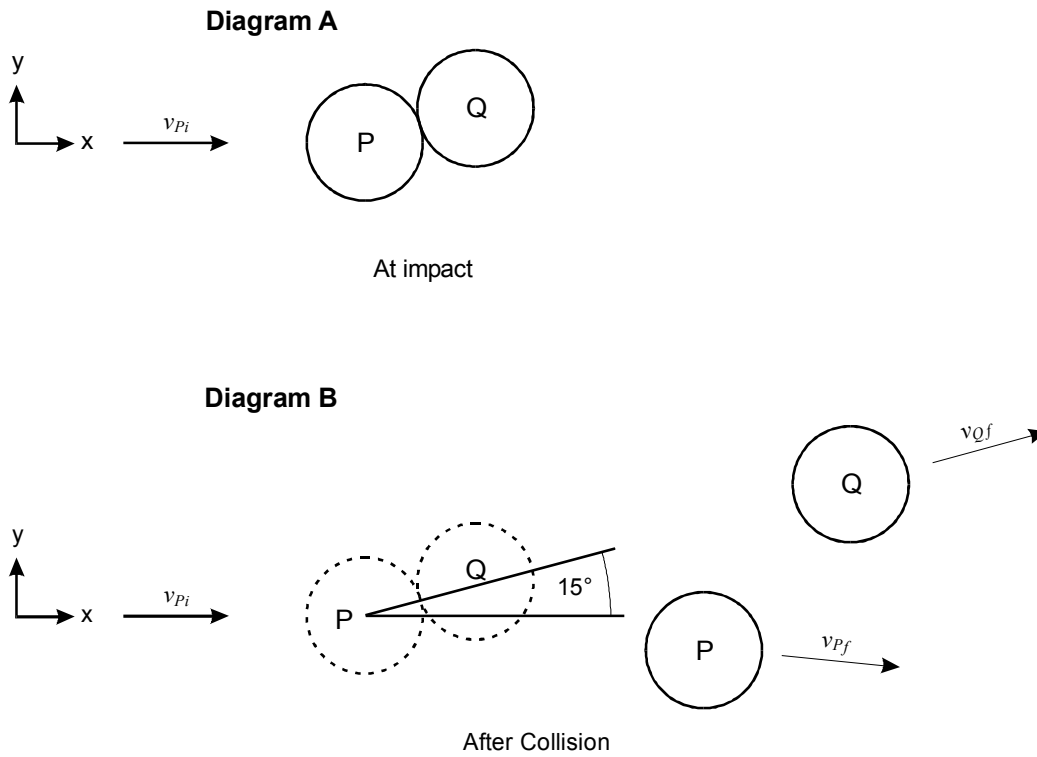

Ball Q has a mass of 0.0470 kg and is at rest. Ball P has a mass of 2.12 kg and is moving in the x -direction toward ball Q with a velocity of 4.64 m/s. Ball P collides with ball Q (Diagram A). After the collision, the path of ball Q is 15.0° above the x -axis, and the x -component of the velocity of ball P is 3.50 m/s (Diagram B).

- Calculate the angle between the final path of ball Q and the final path of ball P immediately after the collision. Show your work.
- List three assumptions about this system that you made in solving this problem.

18. Use the diagram below to complete the exercise that follows.

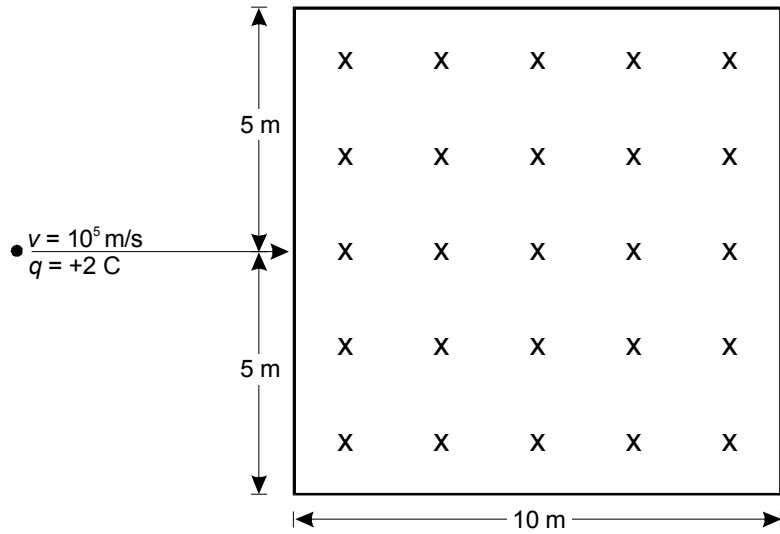

A positively charged particle of charge $q = +2 \text{ C}$ and mass $m = 10^{-4} \text{ kg}$ has a velocity of $v = 10^5 \text{ m/s}$. The particle enters the center of one side of a magnetic field. The field is $\mathbf{B} = 2 \text{ T}$. Its direction is into the page, and its size is $10 \text{ m} \times 10 \text{ m}$.

- What is the shape of the path that the particle follows when it is in the magnetic field? Explain your reasoning.
- Find the key dimension(s) of the path. Show your work.
- Draw the path of the particle on a diagram. Show the location and scale.

CONTINUE YOUR RESPONSE HERE

A large grid of horizontal lines for writing, bounded by vertical margins. The grid consists of 25 horizontal lines. The left margin is marked with a vertical dashed line and the text "DO NOT WRITE OUTSIDE THESE MARGINS". The right margin is marked with a vertical solid line and the text "DO NOT WRITE OUTSIDE THESE MARGINS".

DO NOT WRITE OUTSIDE THESE MARGINS

DO NOT WRITE OUTSIDE THESE MARGINS

DO NOT WRITE OUTSIDE THESE MARGINS

L PAGE 4

STOP. END OF ASSIGNMENT 1.

Annotated Responses to Sample Multiple-Choice Questions for CSET: Science Subtest III: Physics

Motion and Forces

- Correct Response: A.** (SMR Code: 1.1) The initial vertical component of the ball's velocity can be found from triangle trigonometry using $\sin 30^\circ = \frac{v_y}{v_i} = \frac{v_{yi}}{20 \text{ m/s}}$, so $v_{yi} = 10 \text{ m/s}$. The instantaneous vertical velocity at 5.1 m can be calculated using $v_{yf}^2 = v_{yi}^2 + 2a\Delta y = (10 \text{ m/s})^2 + 2(-9.8 \text{ m/s}^2)(5.1 \text{ m}) = 0.04 \text{ m}^2/\text{s}^2$, so $v_{yf} = 0.2 \text{ m/s}$.
- Correct Response: B.** (SMR Code: 1.1) For rotational motion, kinematics gives the angular displacement as $\Delta\theta = \omega_i t + \frac{1}{2}\alpha t^2$, where $\omega_i = 0$ and $\alpha = 0.50 \text{ rad/s}^2$. Substituting these values into the equation gives 2.25 radians, or 2.3 radians to two significant figures.
- Correct Response: B.** (SMR Code: 1.1) By symmetry, cables P and Q each support half the weight of the object, whose weight is $W = mg = (4.0 \text{ kg})(9.8 \text{ m/s}^2) = 39.2 \text{ N}$. The tension in cable P is directed at 45 degrees to the horizontal. From triangle trigonometry, the vertical component of this tension, which is the force supporting half the weight of the object, is found from $\sin 45^\circ = \frac{T_y}{T}$, so that $T_y = T \sin 45^\circ = 0.71T$. But $T_y = \frac{1}{2}(39.2 \text{ N}) = 19.6 \text{ N} = 0.71T$. Solving for T gives, to two significant figures, 28 N.

Conservation of Energy and Momentum

- Correct Response: C.** (SMR Code: 2.1) As the block falls, it loses potential energy. This becomes translational kinetic energy of the block and rotational kinetic energy of the wheel. In other words, $-\Delta U_{\text{block}} = \Delta K_{\text{block}} + \Delta K_{\text{wheel}}$. The wheel's change in potential energy is $mg\Delta h = (2.0 \text{ kg})(9.8 \text{ m/s}^2)(-1.0 \text{ m}) = -19.6 \text{ J}$. Since the block and wheel start at rest, the change in kinetic energy for each object is equal to the final kinetic energy for each object. The block's final kinetic energy is $\frac{1}{2}mv^2 = \frac{1}{2}(2.0 \text{ kg})(2.8 \text{ m/s})^2 = 7.84 \text{ J}$. Substituting these values in the energy equation above yields, to two significant figures, $\Delta K_{\text{wheel}} = 12 \text{ J}$.
- Correct Response: A.** (SMR Code: 2.1) To conserve momentum in a system of colliding objects, all unbalanced forces must act only between objects in the system. No outside forces must affect the objects. In a system isolated in this manner, an object's momentum will change only because of collisions with other objects, which will gain or lose momentum with respect to each other. The overall system momentum will stay constant, however.

6. **Correct Response: D.** (SMR Code: 2.1) The impulse imparted to an object equals the change in the object's momentum. On a force-versus-time graph, impulse is also the area under the graph, which in this case equals $16 \text{ kg}\cdot\text{m/s}$. The 10 kg object, initially moving at 4.0 m/s , has an initial momentum of $40 \text{ kg}\cdot\text{m/s}$. Its final momentum, therefore, is $40 \text{ kg}\cdot\text{m/s} + 16 \text{ kg}\cdot\text{m/s} = 56 \text{ kg}\cdot\text{m/s}$.

Heat and Thermodynamics

7. **Correct Response: D.** (SMR Code: 3.1) The temperature of a sample of gas can be thought of either as a measure of the average kinetic energy of the gas's molecules or as a measure of the gas's internal energy. In either case, this gas's temperature is held constant, so neither quantity changes, which eliminates response choices A and C. Doing 140 J of work on a gas does not necessarily change the gas's entropy, and if the entropy changes, it does not necessarily change by the same numerical amount as the work done. Furthermore, the correct units of entropy are joules/kelvin. The 140 J of work done on the gas are transferred to the water bath in the form of heat energy.
8. **Correct Response: D.** (SMR Code: 3.1) According to the ideal gas law, $PV = nRT$. Here, $P = 10^5 \text{ Pa} = 10^5 \text{ N/m}^2$, $n = 4.0 \text{ moles}$, the gas constant $R = 8.31 \text{ J/K}\cdot\text{mol}$, and $T = 200 \text{ K}$. Substituting and solving for V gives $V = 0.0665 \text{ m}^3$. Since $1 \text{ m}^3 = 1000 \text{ L}$, the volume is 66.5 L , so a 67-liter container should be used for the gas.
9. **Correct Response: D.** (SMR Code: 3.1) The density of the plasma generated from the mercury vapor is very low, around 10^{15} charged particles per cubic meter. As a result, the extremely high temperature of the plasma is balanced by an extremely low heat capacity. Very little of the energy from the disassociated electrons and ions in the plasma is given off as heat.

Waves

10. **Correct Response: C.** (SMR Code: 4.1) Of the response choices provided, only increased tension will increase the frequency of a string's vibration. Given a string of particular mass and length, the speed of the waves along it is affected solely by the force (tension) needed to keep the string stretched. When this force is increased, the wave speed is increased, causing more waves per unit time to travel the same length of string.
11. **Correct Response: C.** (SMR Code: 4.1) When a wave pulse strikes the boundary between two strings, part of the pulse is transmitted along the heavy string at velocity v_2 . Since the second string is denser, however, most of the pulse is reflected back at velocity v_1 . The light string exerts an upward force at the boundary, causing an upright transmitted pulse, while the heavy string exerts a downward force, causing an inverted reflected pulse.

12. **Correct Response: B.** (SMR Code: 4.1) Since image P' is inverted, the focal point of the mirror must lie between the image and the mirror. As shown in the diagram below, two reference rays passing through the tips of both object P and image P' identify the focal point's location at B . Ray 1 goes parallel to the axis from P to the mirror and is reflected through the focal point at point B ; ray 2 goes through B to the mirror and is reflected back parallel to the axis through P' .

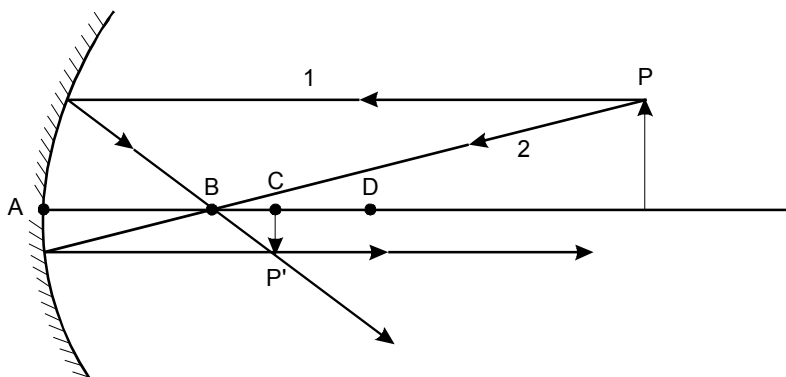

Electromagnetism

13. **Correct Response: C.** (SMR Code: 5.1) The flow of electric charge to the sphere can be thought of as a current, I , of magnitude $160 \mu\text{C/s}$, or $160 \mu\text{A}$, or $1.6 \times 10^{-4} \text{ A}$. This current flows across a potential difference, V , of 75 kV , or $7.5 \times 10^4 \text{ V}$. The power needed to do this is $P = VI = (7.5 \times 10^4 \text{ V})(1.6 \times 10^{-4} \text{ A}) = 12 \text{ V} \cdot \text{A} = 12 \text{ W}$.
14. **Correct Response: D.** (SMR Code: 5.1) The top two resistors are in parallel, so their equivalent resistance is derived from $\frac{1}{R_{\text{eq}}} = \frac{1}{R} + \frac{1}{R} = \frac{2}{R}$, so $R_{\text{eq}} = \frac{R}{2}$. The potential drop across the two branches of the circuit—branch A and branch B—must be equal, since those two branches are also in parallel. If these voltage drops are V_A and V_B , respectively, then $V_A = V_B$, or from Ohm's Law, $I_A R_A = I_B R_B$. Since R_A is half of R_B , I_A must be twice I_B , so the ratio of I_A to I_B is two.

Quantum Mechanics and the Standard Model of Particles

15. **Correct Response: D.** (SMR Code: 6.1) Bohr based his model of atomic structure on Kepler's laws of planetary motion. Contrary to classical mechanics, however, electrons do not follow any possible orbit within a continuous range, but are limited to specific orbits. Bohr theorized that when an electron makes a transition from one orbit to another closer to the nucleus, it emits a discrete amount of energy.

Examples of Responses to Sample Constructed-Response Questions for CSET: Science Subtest III: Physics

Motion and Forces

Question #16 (Score Point 3 Response)

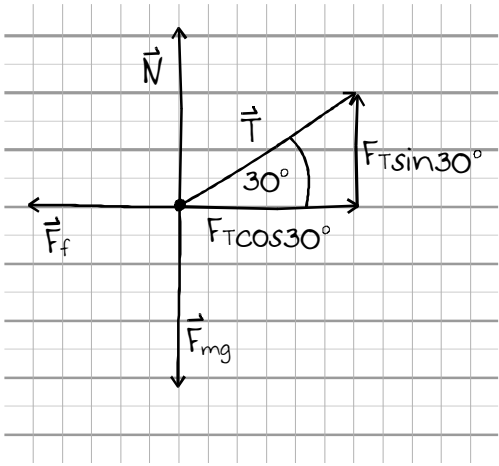

$\Sigma F_x = 0 = F_f + F_T \cos 30^\circ$
 $F_f = 110 \cos 30^\circ = 95 \text{ N}$
 $\Sigma F_y = 0 = F_{mg} + F_N + T \sin 30^\circ$
 $N = F_{mg} - T \sin 30^\circ =$
 $245 - 55 = 190 \text{ N}$

$F_f = \mu_k N$
 $\mu_k = F_f / N$
 $\mu_k = 95 / 190 = 0.50$

Question #16 (Score Point 2 Response)

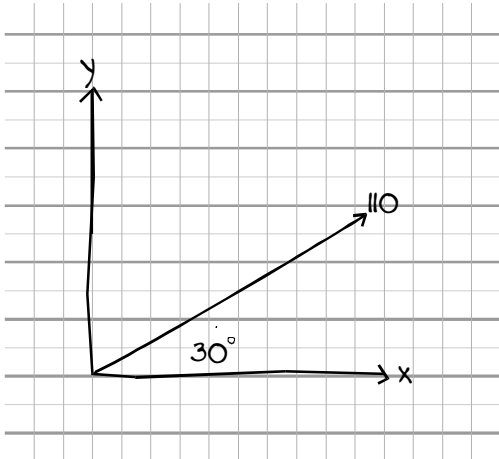
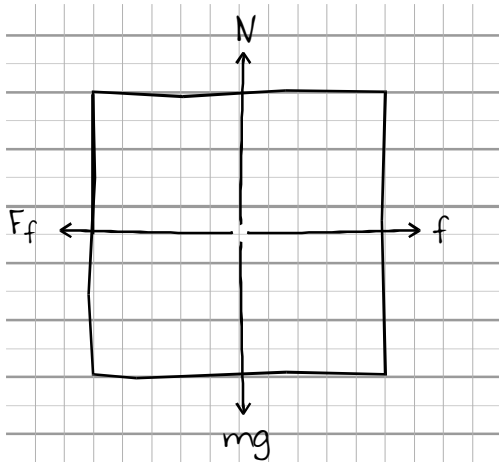

$$\sin 30^\circ = \frac{\text{opp}}{\text{hyp}} = \frac{y}{110} = 55 \text{ N}$$

$$\cos 30^\circ = \frac{\text{adj}}{\text{hyp}} = \frac{x}{110} \text{ so } x = 95.2 \text{ N}$$

$$\mu = \frac{F}{N} = \frac{95.2 \text{ N}}{245 \text{ N}} = 0.39$$

Question #16 (Score Point 1 Response)

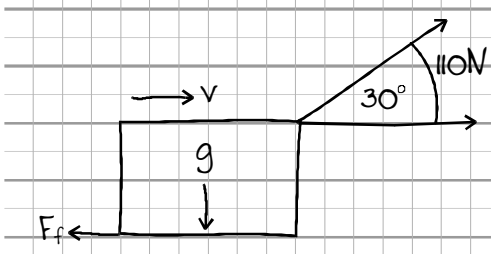

110 N - $\cos 30^\circ = F_x \rightarrow$
 $F_x - F_f = F_y \text{ total}$

Conservation of Energy and Momentum

Question #17 (Score Point 3 Response)

By conservation of momentum $\vec{P}_{\text{initial}} = \vec{P}_{\text{final}}$

This is a vector equation so it implies two equations

x-direction:

$$m_P v_{Px_i} + m_Q v_{Qx_i} = m_P v_{Px_f} + m_Q v_{Qx_f}$$

$$(2.12 \text{ kg})(4.64 \text{ m/s}) + 0 = (2.12 \text{ kg})(3.50 \text{ m/s}) + 0.0470 \text{ kg } v_{Qx_f}$$

$$9.84 = 7.42 + 0.0470 \text{ kg } v_{Qx_f}$$

$$v_{Qx_f} = 51.4 \text{ m/sec.}$$

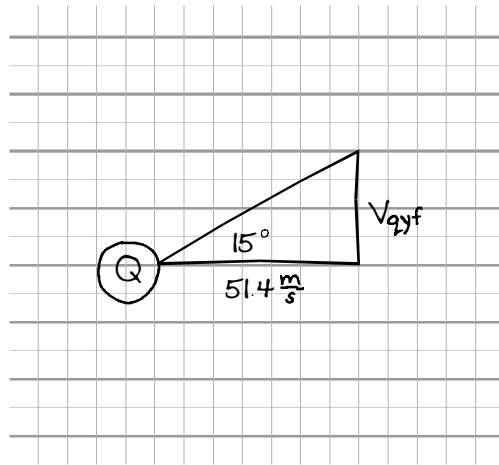

From the diagram it follows that $v_{Qyf} = (\tan 15^\circ)(51.4 \text{ m/s})$

$$v_{Qyf} = 13.8 \text{ m/s}$$

$$\vec{P}_{y_i} = 0 \Rightarrow m_Q v_{Qy} = m_P v_{Py}$$

$$\text{or } (0.0470 \text{ kg})(13.8 \text{ m/s}) = -2.12 \text{ kg } (v_{Py})$$

$$v_{Py} = -0.305 \text{ m/s}$$

continued on next page

Question #17 (Score Point 3 Response) *continued*

To find the angle

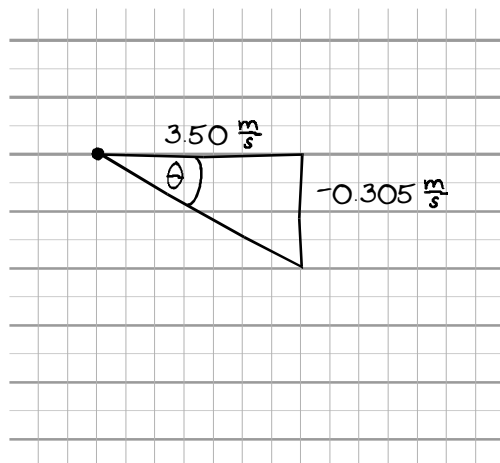

$$\tan \theta = \frac{-0.305}{3.5}$$

$$\theta = 4.98 \cong 5^\circ$$

So the angle between the path of the two balls is 20° .

Three assumptions made in solving this problem are: there are no external forces acting on the system, the balls are not rolling, and the collision is elastic.

Question #17 (Score Point 2 Response)

$$2.42 = .047 V$$

ϕ around 5°

$$v = 51.4 \text{ m/s}$$

so 20°

$$v = 13.8$$

$$v = -0.305$$

assumption:

conservation of momentum

Question #17 (Score Point 1 Response)

Calculate the \angle after the collision of P + Q relative to each other. Using a protractor the \angle is more or less $20-25^\circ$. Assume that P + Q are elastic, with no friction, and of different materials.

Electromagnetism

Question #18 (Score Point 3 Response)

A charged q in a magnetic field experiences a force $= F = qv \times B$. The direction of F is \perp to both $B + v$. \therefore the F will be in the plane of the paper and \perp to the direction of v . Centripetal F on uniform circular motion shows the motion of the q must be circular if the F_{mag} is perpendicular to the velocity of the charge.

$$F = qvB \quad F = 2C \times 10^5 \text{ m/s} \times 2T$$

$$a_B = F/m = (qvB)/m \quad a_B = 4 \times 10^5 / 10^{-4} = 4 \times 10^9 \text{ m/s}^2$$

$$r = mv^2/(qvB) \quad r = 10^{10} / (4 \times 10^9) = 2.5 \text{ m}$$

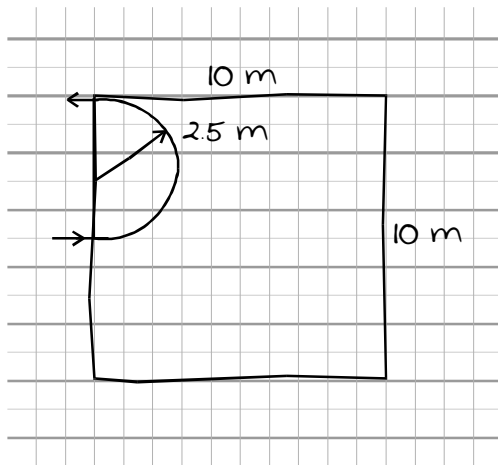

not to scale

in at 5 m

out at 10 m edge

Question #18 (Score Point 2 Response)

$$F = qvB$$

The shape of the path is circular because of the right hand rule

$$F = qvB \quad qvB = \frac{mv^2}{r} \text{ so } r = \frac{mv}{qB} = \frac{(10^{-4} \text{ kg}) (10^5)}{(2q) 2T}$$

$$F = \frac{mv^2}{r} \quad r = 2.5 \text{ m}$$

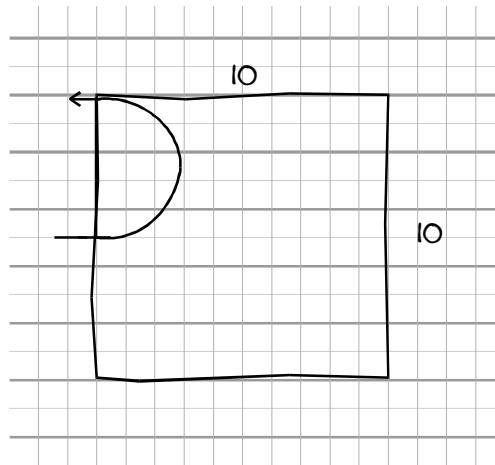

Question #18 (Score Point 1 Response)

A charged particle experiences a force when it moves through a magnetic field. F is greatest when it moves perpendicular to the lines of force. Particles curve in the field, if the magnetic F is strong the particles will form a circle.

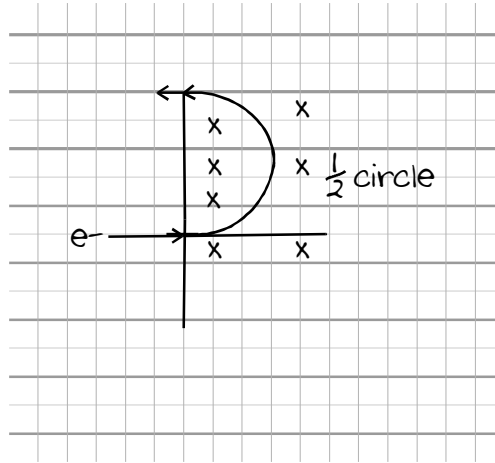

Scoring Information for CSET: Science Subtest III: Physics

Responses to the multiple-choice questions are scored electronically. Scores are based on the number of questions answered correctly. There is no penalty for guessing.

There are three constructed-response questions in Subtest III: Physics of CSET: Science. Each of these constructed-response questions is designed so that a response can be completed within a short amount of time—approximately 10–15 minutes. Responses to constructed-response questions are scored by qualified California educators using focused holistic scoring. Scorers will judge the overall effectiveness of your responses while focusing on the performance characteristics that have been identified as important for this subtest (see below). Each response will be assigned a score based on an approved scoring scale (see page 33).

Your performance on the subtest will be evaluated against a standard determined by the California Commission on Teacher Credentialing based on professional judgments and recommendations of California educators.

Performance Characteristics for CSET: Science Subtest III: Physics

The following performance characteristics will guide the scoring of responses to the constructed-response questions on CSET: Science Subtest III: Physics.

PURPOSE	The extent to which the response addresses the constructed-response assignment's charge in relation to relevant CSET subject matter requirements.
SUBJECT MATTER KNOWLEDGE	The application of accurate subject matter knowledge as described in the relevant CSET subject matter requirements.
SUPPORT	The appropriateness and quality of the supporting evidence in relation to relevant CSET subject matter requirements.

Scoring Scale for CSET: Science Subtest III: Physics

Scores will be assigned to each response to the constructed-response questions on CSET: Science Subtest III: Physics according to the following scoring scale.

SCORE POINT	SCORE POINT DESCRIPTION
3	<p>The "3" response reflects a command of the relevant knowledge and skills as defined in the subject matter requirements for CSET: Science.</p> <ul style="list-style-type: none"> • The purpose of the assignment is fully achieved. • There is an accurate application of relevant subject matter knowledge. • There is appropriate and specific relevant supporting evidence.
2	<p>The "2" response reflects a general command of the relevant knowledge and skills as defined in the subject matter requirements for CSET: Science.</p> <ul style="list-style-type: none"> • The purpose of the assignment is largely achieved. • There is a largely accurate application of relevant subject matter knowledge. • There is acceptable relevant supporting evidence.
1	<p>The "1" response reflects a limited or no command of the relevant knowledge and skills as defined in subject matter requirements for CSET: Science.</p> <ul style="list-style-type: none"> • The purpose of the assignment is only partially or not achieved. • There is limited or no application of relevant subject matter knowledge. • There is little or no relevant supporting evidence.
U	<p>The "U" (Unscorable) is assigned to a response that is unrelated to the assignment, illegible, primarily in a language other than English, or does not contain a sufficient amount of original work to score.</p>
B	<p>The "B" (Blank) is assigned to a response that is blank.</p>